

CN1A PB00 SERIES

Current Sensor

Model Number:

CN1A 25 PB00

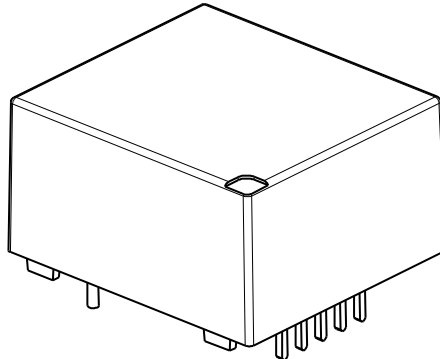

For the electronic measurement of voltage: DC, AC, pulsed..., with galvanic separation between the primary and the secondary circuit.

Features

- ✧ Closed loop (compensated) current sensor using the Hall Effect
- ✧ Galvanic separation between primary and secondary
- ✧ Insulating plastic case recognized according to UL94-V0
- ✧ Very good linearity
- ✧ High accuracy
- ✧ Very low offset drift over temperature
- ✧ No insertion loss
- ✧ Standards:
 - IEC 60664-1:2020
 - IEC 61800-5-1:2022
 - IEC 62109-1:2010

Applications

- ✧ AC variable speed and servo motor drives
- ✧ Uninterruptible Power Supplies (UPS)
- ✧ Static converters for DC motor drives
- ✧ Switch Mode Power Supplies (SMPS)
- ✧ Power supplies for welding applications
- ✧ Battery management
- ✧ Wind energy inverter
- ✧ Test and detection devices

Safety

This sensor must be used according to IEC61800-5-1.

This sensor must be used in electric/electronic equipment with respect to applicable standards and safety requirements in accordance with the following manufacture's operating instructions.

Caution, risk of electrical shock!



When operating the sensor, certain parts of the module can carry hazardous voltage (e.g., Primary busbar, power supply). Ignore this warning can lead to injury and/or cause serious damage.

This sensor is a built-in device, whose conducting parts must be inaccessible after installation. A protective housing or additional shield could be used.

Main supply must be able to be disconnected.

CN1A PB00 SERIES

Absolute maximum ratings (not operating)

Parameter	Symbol	Unit	Value
Supply voltage	V_c	V	± 18

- ※ Stress above these ratings may cause permanent damage.
- ※ Exposure to absolute maximum ratings for extended periods may degrade reliability.

Environmental and mechanical characteristics

Parameter	Symbol	Unit	Min	Typ	Max	Comment
Ambient operating temperature	T_A	°C	-40		85	
Ambient storage temperature	T_S	°C	-40		90	
Mass	m	g		23		

Insulation coordination

Parameter	Symbol	Unit	Value	Comment
Rms voltage for AC insulation test @ 50Hz, 1min	V_d	kV	2.5	According to IEC 60664-1
Impulse withstand voltage 1.2/50μs	V_w	kV	9	
Insulation resistance	R_{IS}	MΩ	1500	@500V, $T_A=25^\circ\text{C}$
Plastic case	-	-	UL94-V0	
Clearance (pri.- sec.)	d_{Cl}	mm	10.6	
Creepage distance (pri.- sec.)	d_{Cp}	mm	10.6	
Comparative tracking index	CTI	PLC	3	
Application example	-	-	600V	Reinforced insulation, according to IEC 61800-5-1, IEC 62109-1CAT III, PD2
Application example	-	-	1700V	Basic insulation, according to IEC 61800-5-1, IEC 62109-1CAT III, PD2

CN1A PB00 SERIES

Electrical data

※ With $T_A = 25^\circ\text{C}$, $V_C = \pm 15\text{V}$, $R_L = 150\Omega$, unless otherwise noted.

Parameter	Symbol	Unit	Min	Typ	Max	Comment
Primary nominal rms current	I_{PN}	At		± 25		
Maximum measuring current	I_{PM}	At	-36		36	
Measuring resistance	R_M	Ω	100		320	@70°C, $\pm 25\text{At}$
			100		315	@85°C, $\pm 25\text{At}$
			100		190	@70°C, $\pm 36\text{At}$
			100		185	@85°C, $\pm 36\text{At}$
Primary resistance (each coil)	R_P	m Ω			1.25	@ 25°C
Secondary coil resistance	R_S	Ω		115		@ 85°C
Output nominal rms current	I_{SN}	mA		± 25		
Supply voltage	V_C	V		± 15		@ $\pm 5\%$
Coil turn ratio	K_N	-	1-2-3-4-5:1000			
Current consumption	I_C	mA		$10 + I_S$		
Zero offset current	I_0	mA	-0.15	± 0.05	0.15	
Thermal drift of offset current	I_{0T}	mA	-0.5	± 0.15	0.5	@ -25°C~85°C
			-1.2	± 0.30	1.2	@ -40°C~85°C
Residual current@ $I_P=0$ after $3 \times I_{PN}$	I_{0M}	mA	-0.15	± 0.05	0.15	
Sensitivity error	ε_G	%	-0.3		0.3	
Linearity error	ε_L	% of I_{PN}	-0.2		0.2	Exclusive of I_0
Accuracy@ I_{PN}	χ	% of I_{PN}	-0.5		0.5	Exclusive of I_0
Response time@90% of I_{PN}	t_r	μs			1	@ $di/dt=100\text{A/s}$
Frequency bandwidth(-1dB)	BW	kHz	150			

CN1A PB00 SERIES

Dimensions (in mm. 1 mm = 0.0394 inch)

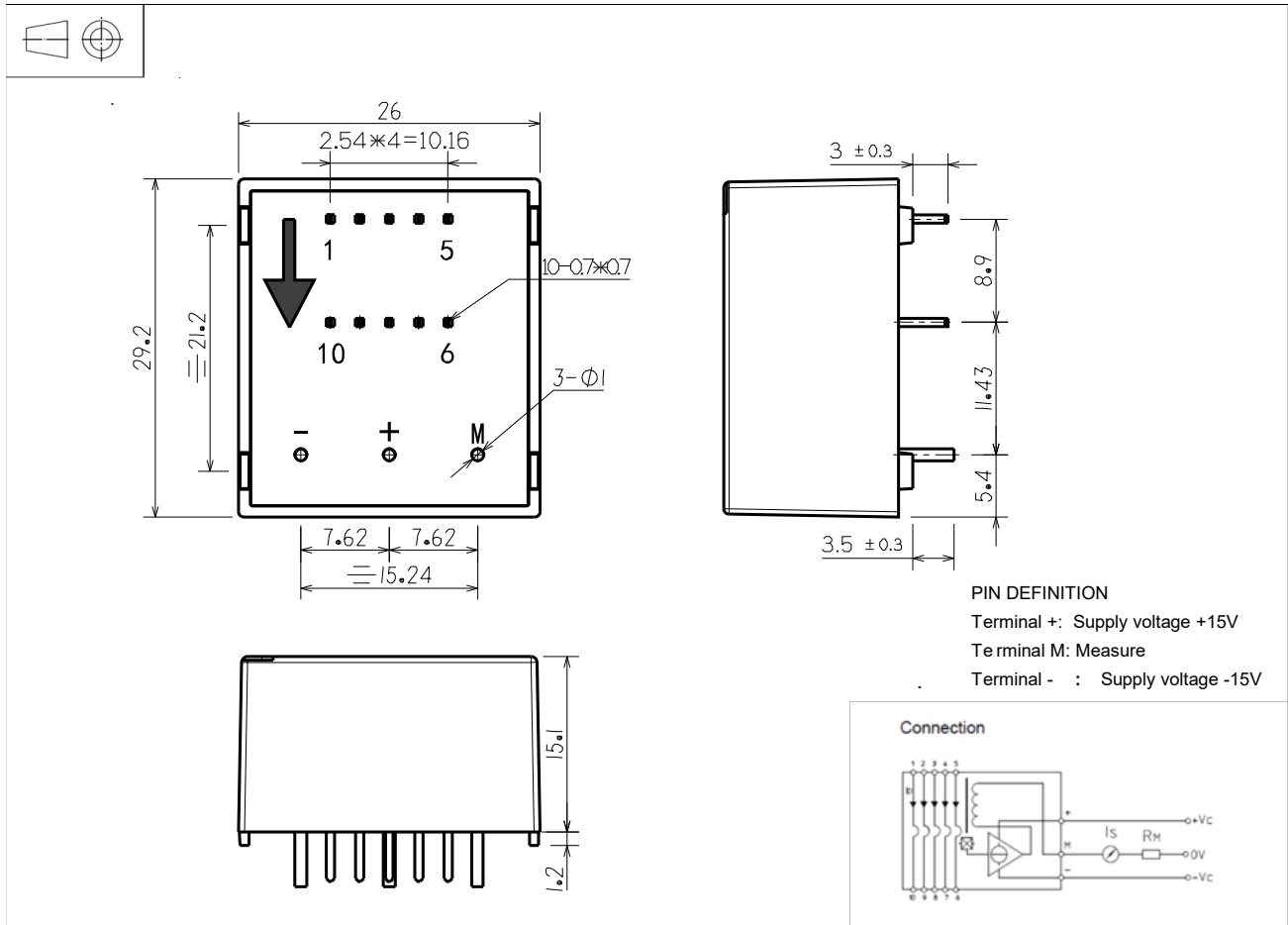

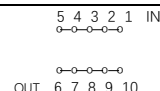
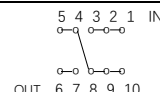
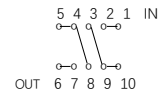
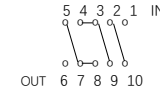
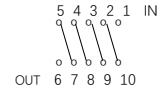
Primary turns	Primary current		Nominal output current $I_{SN}(mA)$	Turns ratio K_N	Primary resistance R_P (mΩ)	Primary inductance L_P (μH)	Connection way
	Nominal current $I_N(A)$	Max. current $I_M(A)$					
1	25	36	25	1 / 1000	0.3	0.023	
2	12	18	24	2 / 1000	1.1	0.09	
3	8	12	24	3 / 1000	2.5	0.21	
4	6	9	24	4 / 1000	4.4	0.37	
5	5	7	25	5 / 1000	6.3	0.58	

CN1A PB00 SERIES

Mechanical characteristics

◇ General tolerance	±0.3 mm
◇ Primary connecting pin	10 pins 0.7×0.7mm
◇ Secondary signal connecting pin	3 pins Φ1mm
◇ Recommended PCB hole	Φ1.2

Remarks

- ◇ I_S is positive when the measured electric current flows from 1,2,3,4,5 to 10,9,8,7,6.
- ◇ This is a standard model. For different applications(measurement, secondary connections...), please contactCHIPSENSE.